

**Notes:**

If you wish to supply +5V from an external power supply (such as a spare PC power supply), omit U1, U2 and D1, and install a connector in place of U1 to supply power.

Do not use U2 unless the current consumption is kept below 100 mA (i.e. you are using the non-PWM firmware).

A heatsink may be required on U1.

There are three different options for the zero-crossing circuit.

First, install R1, R2 and U6, and bring an AC signal into J1. The value of R1 and R2 depends on the magnitude of the AC signal. The 15K values shown are for 110VAC (RMS).

The second possibility is to install R9 and Q1, and supply a 10V (or so) peak full-wave rectified signal on either J4-3 (and jumper J2-1 to J2-2) or on J4-7/8 (and jumper J2-2 to J2-3).

The third possibility is to use an external circuit similar to options one or two, and to bring that signal in through J17.

Do not install R3 or the Diag LED. They are not supported in firmware.

Do not install both U1 and U2

Refer to BOM for exact part numbers of components to purchase.

D3 is mistakenly labelled D4 on both Rev XA and Rev XB Silkscreens (left most D4 on Rev XA). D4 is mistakenly labeled D5 on Rev XB Silkscreen.

Pin numbering on the TO92 parts (Q1 and U2) do not follow convention, but schematic and PCB silkscreen are consistent with each other.

Pins on U3 are numbered 1,4,5,8 CCW from pin 1 U3

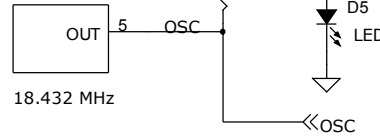

|   |                 |     |
|---|-----------------|-----|
| Title   |                 |     |
| Renard (64 Channel Coop)                      |                 |     |
| Size  | Document Number | Rev |
| B   | NA              | X1  |
| Date: Thursday, October 11, 2007 Sheet 1 of 3 |                 |     |

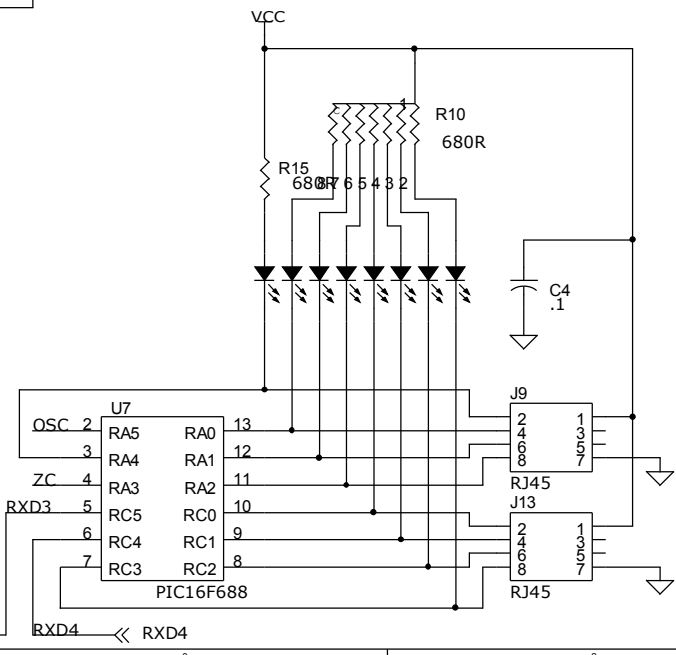
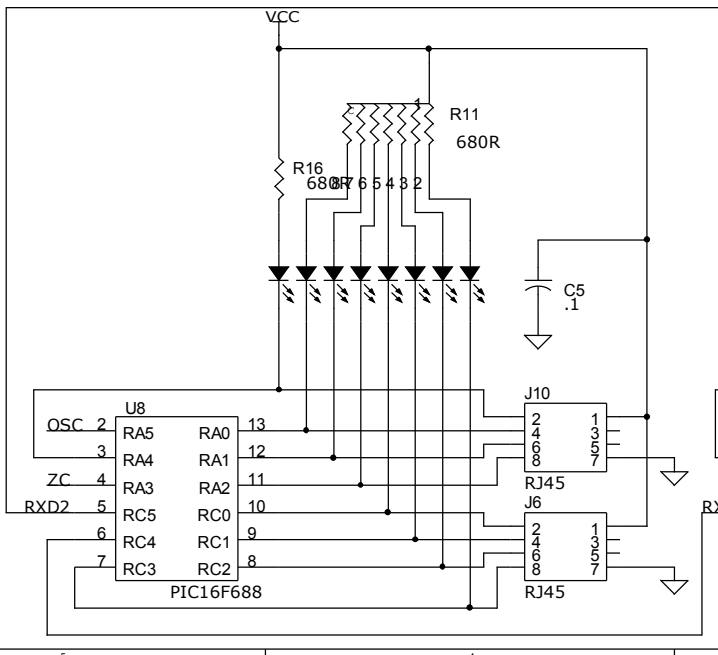
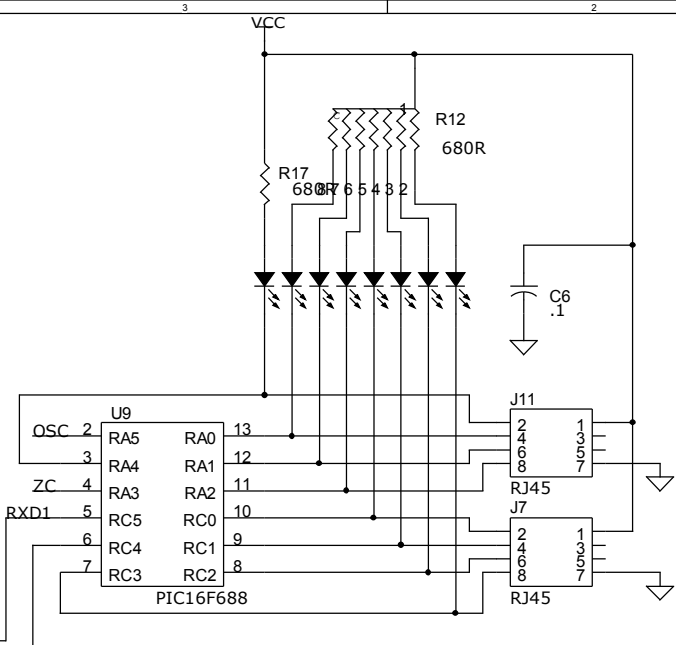
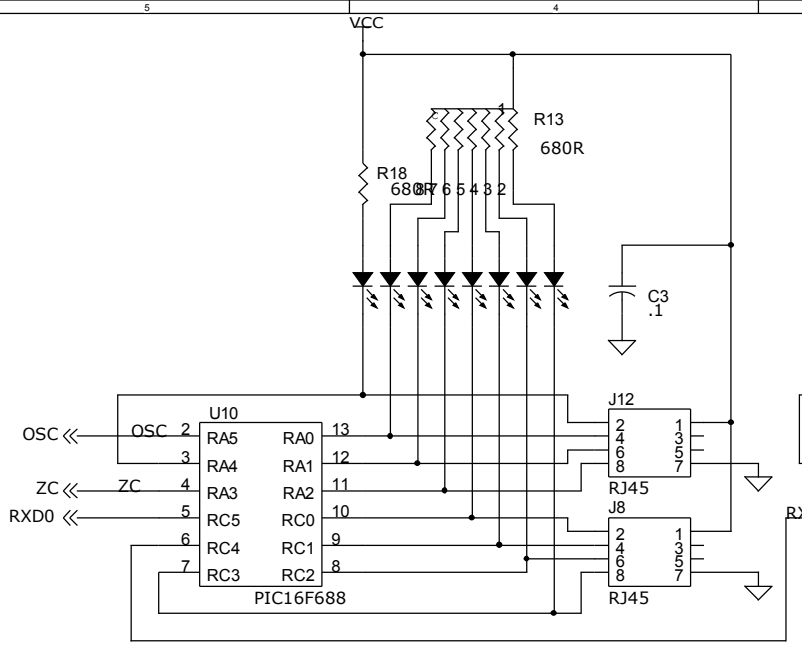

RXD4 << RXD4

|                                  |                 |      |
|----------------------------------|-----------------|------|
| Title                            |                 |      |
| Renard64                         |                 |      |
| Size                             | Document Number | Rev  |
| B                                | NA              | NA   |
| Date: Thursday, October 11, 2007 |                 |      |
| Sheet                            | 2               | of 3 |

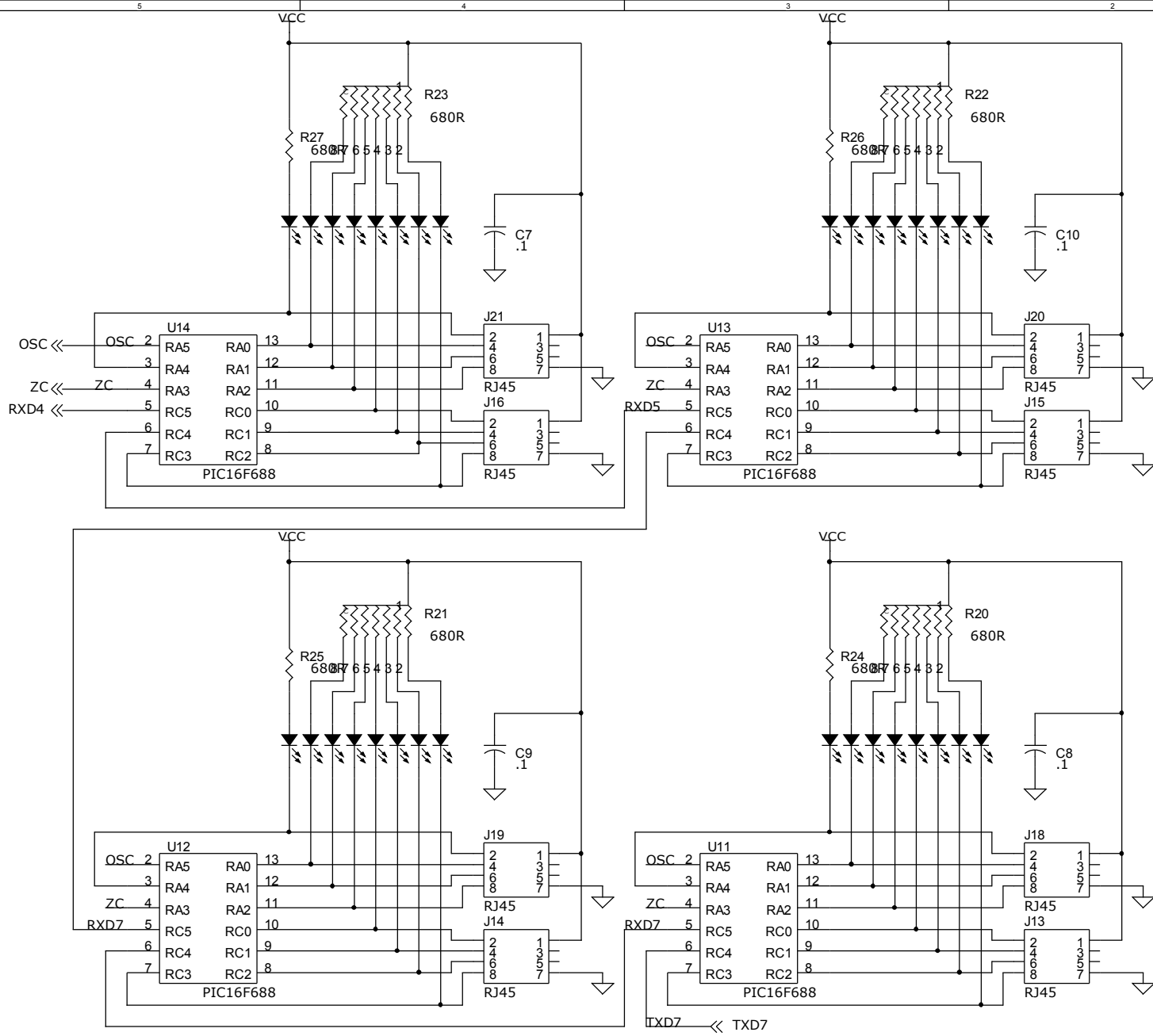

|                                  |                 |              |
|----------------------------------|-----------------|--------------|
| Title                            |                 |              |
| Renard64                         |                 |              |
| Size                             | Document Number | Rev          |
| B                                | NA              | NA           |
| Date: Thursday, October 11, 2007 |                 | Sheet 3 of 3 |